

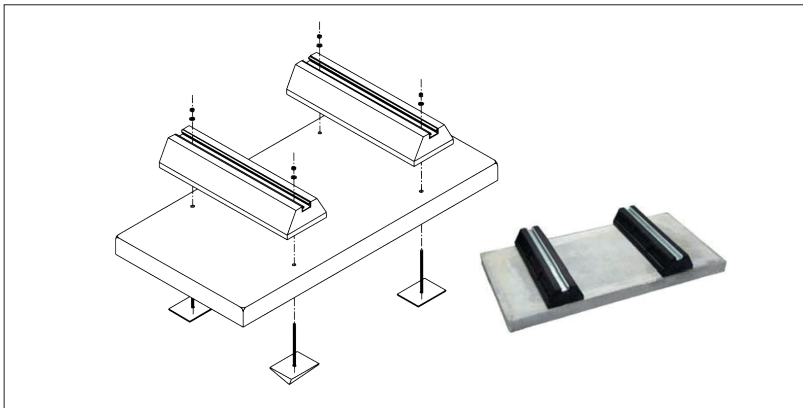

■ FLEXI LITE SLAB AND FOOT KIT

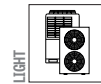

A low cost innovative solution for floor mounting air conditioning units and ASHP. The FLEXI Lite Slab and Foot kit avoids the high cost and time consuming need to construct a concrete base and comes complete with FLEXI rubber mounting feet. It can be delivered to site with minimum preparation and can be assembled in minutes. It also suits most brands of domestic air source heat pumps and air conditioning units.

■ FEATURES

- Low cost and rapid installation time
- Easy to transport and locate
- Safe working load – 600kg
- Simple to construct
- Fixing pack to secure feet to the slab
- Fixing pack to secure a heat pump to the feet

■ RELATED PRODUCTS

- Wooden guard
- ASHP Soakaway
- Collection tray
- Floor bracket kit

■ THE PACKAGE

- Flexi Slab
- 2 or 3 x Flexi Feet
- 4 x fixing plate
- Fixings
- Installation instructions

Part code	Description	Specifications (WxDxH)
FF-UC3-S	Flexi Lite Kit - small	900 x 600 x 175
FF-UC3-M	Flexi Lite Kit - medium	1050 x 600 x 175
FF-UC3	Flexi-Lite Slab Kit	1200 x 600 x 175
FF-UC3-3	Flexi lite Slab Kit - 3 FEET	1200 x 600 x 175
FF-UC3-XL	Flexi-Lite Slab Kit - extra large	1525 x 915 x 75

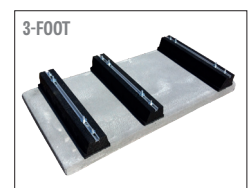
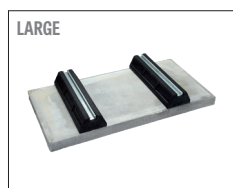
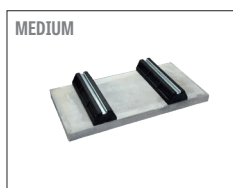

FREEZE/THAW TESTING

The FLEXI Lite Slab has been independently tested to the rigorous freeze-thaw regimen specified by ASTM C67. This standard dictates a twenty five cycle freeze-thaw sequence. The freeze portion of the sequence takes place with the top surface of the slab under 12mm of water. Once twenty five cycles are complete the slab is examined for cracks and crazing. The FLEXI Lite Slab performed flawlessly.

CHEMICAL RESISTANCE

In normal usage conditions an equipment pad can be exposed to a variety of chemicals. The FLEXI Lite Slab has been fully tested in accordance with ASTM D2299 for resistance against: all refrigerants, compressor oils, salt solution and synthetic canine urine.

FLEXI FLEXI LITE SLAB & FOOT KIT

The DiversiTech International sales team are available to answer your questions or queries on this product. Our experts are waiting for your call +44 (0)115 900 5858 or if you prefer send an email to sales@diversitech.com or visit www.diversitech.global



Glaisdale Drive East
Nottingham NG8 4LY
United Kingdom



■ INSTALLATION PROCESS



STEP 1 - Position and mark ground for the required location of the FLEXI Lite Slab.



STEP 2 - Prepare the ground.



STEP 3 - Drill the slab for insertion of pipework and insert the drainage bung.



STEP 4 - Mark the area below the slab for the pipework so that you can lay the drainage pipes prior to finalising the slab install.



STEP 5 - Ensure that slab is level.



STEP 6 - Measure the slab for the placement of the feet. This needs to match the pitch of the unit.



STEP 7 - Place the feet in position, and drill 9mm holes through the feet 50mm from each end.



STEP 8 - Attach all 4 base plates to the underside of the slab.



STEP 9 - Place the feet on the threads.



STEP 10 - Secure the feet with the nuts and washers, and position the spring nuts in the strut.



STEP 11 - The Flexi Lite Slab install is complete and ready for the unit



FLEXI FLEXI LITE SLAB & FOOT KIT

The DiversiTech International sales team are available to answer your questions or queries on this product. Our experts are waiting for your call +44 (0)115 900 5858 or if you prefer send an email to sales@diversitech.com or visit www.diversitech.global

DIVERSITECH[®]
INTERNATIONAL

Glaisdale Drive East
Nottingham NG8 4LY
United Kingdom